

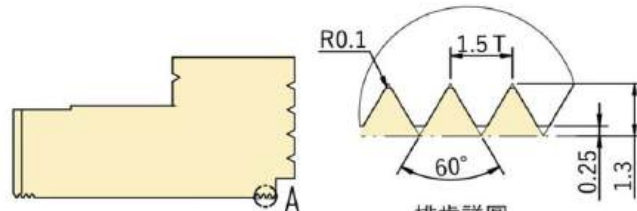

HJ- SERIES

標準硬爪

STANDARD HARD JAWS



排齒詳圖
Drawing of Serration

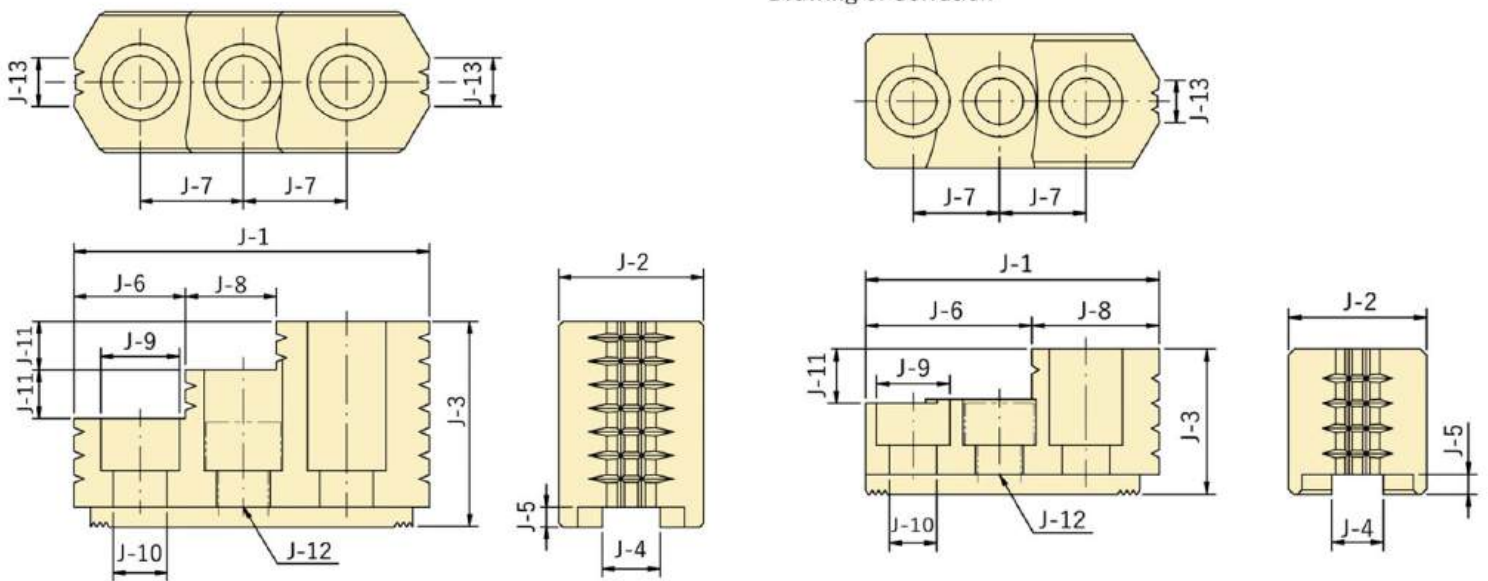

DIMENSION

MODEL	J-1	J-2	J-3	J-4	J-5	J-6	J-7	J-8	J-9	J-10	J-11	J-12	J-13	排齒節距 Serration	參考圖 Reference
HJ-05	53	23	27.5	10	4	30.5	14	25.5	13.5	8.5	10	M8	6	1.5x60°	B
HJ-06	67.5	32	35	12	5	39	20	28.5	17	11	12	M10	10	1.5x60°	B
HJ-08	86	35	51	14	5	31	25	18	19	13	12	M12	12	1.5x60°	A
HJ-10	99.5	40	54	16	5	43	30	17	19	13	13	M12	15	1.5x60°	A
HJ-12	103	50	52	21	5	62.5	30	40.5	25	17	17	M16	30	1.5x60°	B
HJ-12-1	103	50	52	18	5	62.5	30	40.5	22	15	17	M14	30	1.5x60°	
HJ-15	149	62	86	22	8	63	43	34	32	21	20	M20	40	1.5x60°	A
HJ-15-1	149	62	86	25.5	5	63	43	34	32	21	20	M20	40	1.5x60°	
HJ-21	165	65	90	25	9	104.5	50	55	32	21	20	M20	55	3.0x60°	B



HC- SERIES

標準生爪

STANDARD SOFT JAWS

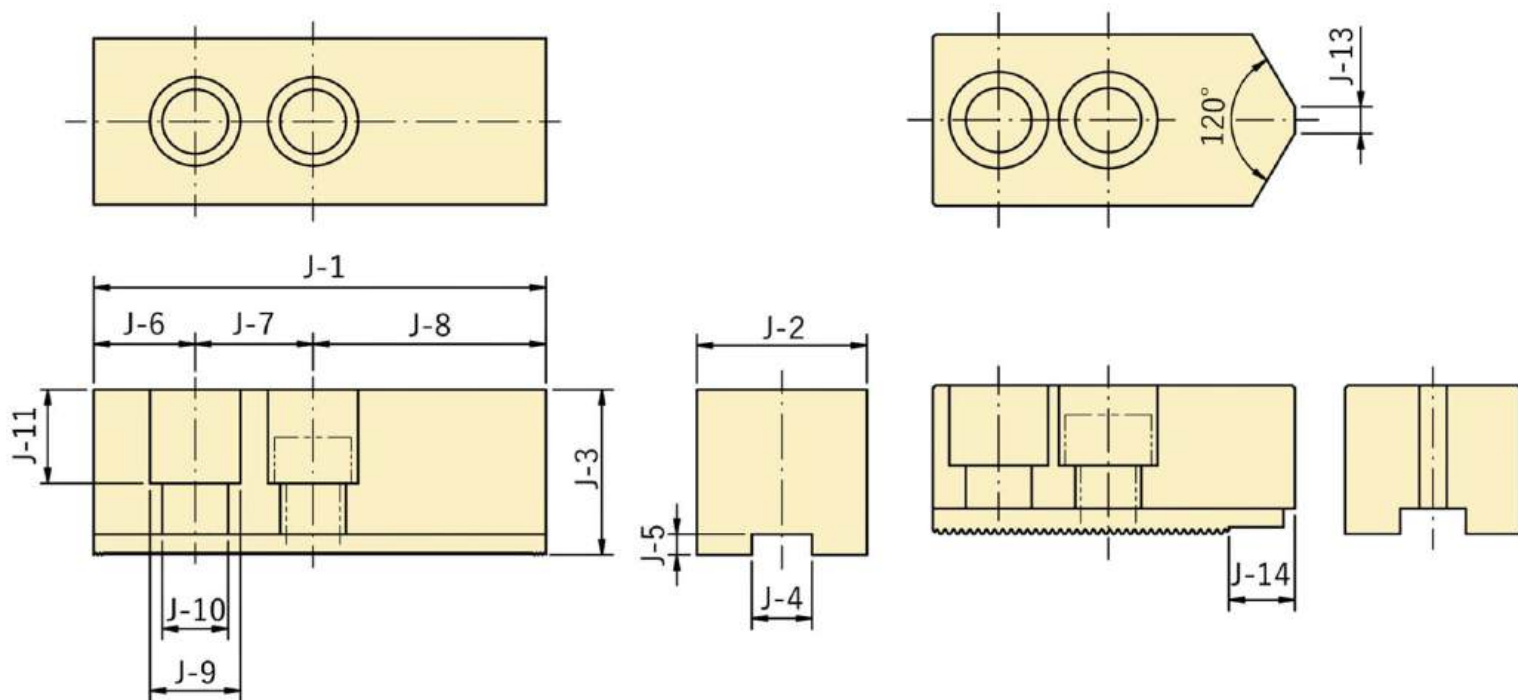

DIMENSION															
MODEL	J-1	J-2	J-3	J-4	J-5	J-6	J-7	J-8	J-9	J-10	J-11	J-12	J-13	J-14	排齒節距 Serration
HC-04	49.5	23	23	10	4	10	14	25.5	13.5	8.5	14	M8	4	-	1.5x60°
HC-05	54	23	25	10	4	12	14	28	13.5	8.5	16	M8	5	-	1.5x60°
HC-06	66	32	28	12	5	12	20	34	17	11	16	M10	5	12	1.5x60°
HC-08	95	35	38	14	5	24	25	46	19	13	23	M12	12	20	1.5x60°
HC-10	110	40	42	16	6	30	30	50	19	13	27	M12	18	20	1.5x60°
HC-12	130	50	50	21	6	39	30	60	25	17	30	M16	18	30	1.5x60°
HC-12-1	130	50	50	18	6	39	30	60	23	15	30	M14	18	30	1.5x60°
HC-15	165	62	62	22	8	37	43	85	32	21	38	M20	-	-	1.5x60°
HC-15-1	135	50	60	25.5	5	26	43	66	32	21	39	M20	-	-	1.5x60°
HC-21	185	62	70	25	9	40	60	85	32	21	46	M20	-	-	3.0x60°